



Innovative Photonic Solutions

# 5570

## Hybrid Modular™ LED Lightlines

### KEY FEATURES

- High Intensity for Linescan
- Long Lifetime: 50,000 hours
- Modular Design, 150mm Units
- Combine Modules up to 2m
- Robust Solid State Design
- Multiple Wavelength Options
- US Pat. & Intl. Patents Pending



### APPLICATIONS

- LCD/OLED Inspection
- Polymer Web Applications
- Rolled Metal Webs
- Glass Sheet Inspection
- Semiconductor Surface
- Paper & Print Inspection

### High Intensity & Long Lifetime

Linescan users can finally have the long lifetime advantage of LEDs without sacrificing the high intensity and uniformity required in these applications. The patented **5570** series Hybrid Modular LED Lightlines provide extremely high intensities in a modular product format, allowing the enduser to construct long lightlines to any final web width desired. Thanks to an innovative optical design, these patented modules fit end-to-end providing seamless illumination with extraordinary uniformity. And the innovative LED lamp units employed not only provide intensities rivaling Tungsten Halogen technologies, but can be easily be snapped into place for replacement or future retrofit. Modules are available in a wide range of wavelengths, including broadband white and tricolor RGB versions. Cylindrical focusing lenses optional.

# Detail Drawing

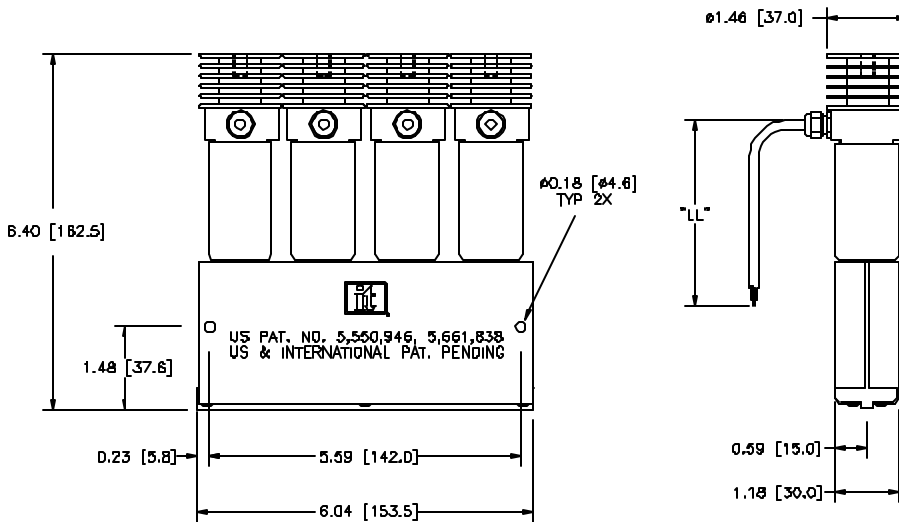

## PART NUMBER

**5570 - WWW - LL**

LL	Length (m)
- 01	1m (39")
- 02	2m (78")
- 03	3m (118")

WWW	Wavelength, Color
-455	455 nm, Deep Blue
-470	470 nm, Blue
-505	505 nm, Light Blue
-530	530 nm, Green
-590	590 nm, Amber
-617	617 nm, Orange/Red
-627	627 nm, Red
-RGB	470/530/530/627nm
-WHT	5500K, White

NOTE: Specifications May Change without Notice

**DXF File Available**

# Technical Specifications

## Average Lifetime

Continuous: 50,000 Hours

## Environmental

Temperature: 0 to 35C  
Relative Humidity: 0 to 95%

## Electrical

455-530nm, WHT: 700mA/Lamp  
590-627nm 1000mA/Lamp

## Output Comparisons (75mm Distance)

Wavelength	Photometric (lux)	Radiometric (mW/cm <sup>2</sup> )	Silimetric (sW/cm <sup>2</sup> ) <sup>+</sup>
455 nm	102,000	50.5	30.5
470 nm	336,000	77.0	48.0
505 nm	828,000	36.0	24.0
530 nm	1,150,000	37.0	25.5
590 nm	528,000	12.0	10.0
617 nm	685,000	47.0	42.0
627 nm	925,000	73.0	69.0
White	550,000	23.0	16.5
150W TH*	1,150,000	125.0	111.5

\* Comparative output of a 150W Tungsten Halogen lightsource (80% drive) powering a 150mm Modular Fiberoptic Lightline with  $\phi$ 50mm Cylindrical Focusing Lens (75mm working distance)

+ Artificial units developed by Illumination Technologies to more accurately predict the relative output signals generated by various wavelengths using silicon based detector systems, including CCD and CMOS cameras. For more detailed information on this topic visit our website and download Tech Note #125 - "Correct Measurement Units"

Proudly Distributed By:



## Illumination Technologies, Inc.

5 Adler Drive • East Syracuse • New York 13057 USA  
TEL: 315-463-4673 • FAX: 315-463-1401 • Toll Free (North America): 800-738-4297  
Web: <http://www.illuminationtech.com> • E-mail: [info@illuminationtech.com](mailto:info@illuminationtech.com)

© 2006 Illumination Technologies